



ELECTRIC WALKIE STACKER DAILY CHECKLIST

DATE	<input type="text"/>	INSPECTED BY	<input type="text"/>
MAKE	<input type="text"/>	MODEL	<input type="text"/>
		S/N#	<input type="text"/>
HOUR	<input type="text"/>	VOLTAGE	<input type="text"/>

MARK BOX If NO PROBLEMS Visible. KEEP UNMARKED and WRITE IN Comment if PROBLEMS ARE PRESENT.

VISUAL INSPECTION

Comments

1. Main ON/OFF Switch _____
2. Hour Meter _____
3. Key Switch _____
4. Spec Plate Location _____
5. Directional/Speed Control _____
6. Emergency Reverse Button _____
7. Horn Button _____
8. Lift/Lower Button/Lever _____
9. Battery _____
 Vent Caps _____
 Connector Covers _____
 Cables _____
 Water Level _____
10. Lift Cylinder _____
11. Forks _____
12. Load Wheels _____
13. Drive Wheel _____
14. Caster Wheel _____

OPERATIONAL INSPECTION

Comments

- A. Listen for Unusual Noise _____
- B. Lifting Control _____
- C. Forward Driving _____
 Accelerator _____
 Steering _____
 Braking _____
- D. Reverse Driving _____
 Accelerators _____
 Steering _____
 Braking _____
 Backup Alarm _____
- E. Horn _____
- F. Gauges _____
- G. Oil Spots on Floor _____

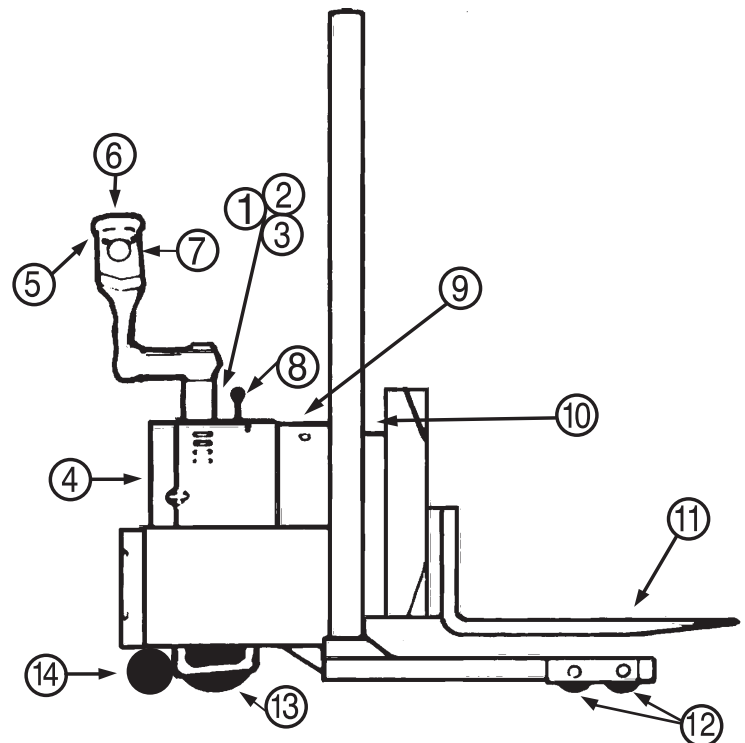

SIGNATURE: _____

All comments made in reference to any problems should be made on the back of this page in detail and handed to the supervisor immediately.

CAUTION: This is not a complete list of all items which may require attention. Operators are responsible for ensuring that the lift truck is in proper working condition in accordance with the manufacturer's specifications.

DO NOT operate lift truck if a problem is detected.
Report all problems to the service department immediately.