



CUSHION TIRE FORKLIFT

7,000-8,000 LB CAPACITY LP GAS MODELS

DURABILITY AND STRENGTH YOU CAN RELY ON



BUILT FOR UPTIME

TO KEEP YOUR OPERATION RUNNING.



- Built-in features to protect the truck
- Limiting downtime with increased ease of serviceability
- More time between scheduled maintenance
- Real time communication from the truck itself

Protect your margins and your productivity with trucks designed to stay running.

A Truck That Keeps Its Cool: The effective cooling system of the truck is equipped with a 10-blade fan and aluminum radiator that utilizes cross flow cooling to make sure that fluids are kept at a temperature that are conducive to maintaining strong levels of performance and operation. Additionally, the engine compartment is constantly cooled while it works by way of its bottom bypass airflow design.

Minimizing the Downtime That Has to Happen: All forklifts require time to take care of the things that matter to maintain the health of the truck, but with 500 hour extended service intervals, these occurrences can be kept to a minimum. And whenever it comes to the regular tasks required every shift, the critical components are easily accessible for daily checks and there are a number of LP tank bracket options that can help to minimize the effort to switch out the tank for operators of all sizes when its time to refuel.

Self-Diagnosis and Alerts: The truck is able to communicate in a number of ways, including audible and visual alerts to keep the operator informed, as well as on-board diagnostics directly through the display that help to limit the amount of time needed to address issues and help provide as much information as possible, well before a technician can even analyze the situation. Service interval alerts can also be programmed into the truck so there is no question when scheduled maintenance needs to take place.



Parking Brake Transmission Interlock

This feature ensures that when the parking brake is activated, the transmission of the truck cannot engage in travel which can protect the brakes and transmission from potentially damaging activity.



**Additional Options
To Better Fit Your Needs**

- Sideshifter and Fork Positioner options
- Fuel Saver Mode
- Swing Down LP Tank Bracket
- Radiator Screen
- Air Intake Pre-Cleaner
- Debris Packages
- Variety of Working and Combination Lights
- Smart Back-Up Alarm
- Seatbelt/Transmission and Mast Interlock-Variety of Accessories

Ask your local dealer about the available options for improved performance, productivity and operator comfort.

THE COMPLETE OPERATOR EXPERIENCE.

POWER + MANEUVERABILITY + AWARENESS + COMFORT = PRODUCTIVITY



- Smooth, powerful and efficient engines
- Maneuverability and control
- Emissions and regulations compliance

A smaller chassis developed to pack a bigger punch when it comes to productivity.

Proven Powered Performance:

Equipped with the GK25 Internal Combustion LP gas-powered engine, the FGC35CN-FGC40CN forklifts have proven high levels of output and torque when the application demands it, without sacrificing the optimization of the combustion process, by way of the electronic fuel injection system. The three electronic control modules are in constant communication with each other to precisely manage the process through CAN communication, mastering the delicate balance of fuel efficiency and force.



All About Fitting In

Maintaining capacity retention with a smaller chassis footprint allows these forklifts to maneuver in and out of the confined spaces that can exist in a number of warehousing applications, where other lift trucks cannot. Combining the small footprint with the hydrostatic power steering means that operators can confidently work to get product in and out of even the tightest of locations.

Operator Awareness

Whether it is awareness of the status of the truck through the diagnostic display or awareness of their surroundings by way of excellent visibility in all directions from the seat, operator's are free to effectively achieve their goals with enhanced confidence that they are using a forklift designed to get the job done.

Ergonomic Features

A low entry step and three points of contact allow entry and exit into the spacious operator compartment with little effort or stress. Once seated, the operator can adjust both the comfort vinyl seat and adjustable steering column to ensure that they are in the most comfortable position possible, regardless of the length of the shift.

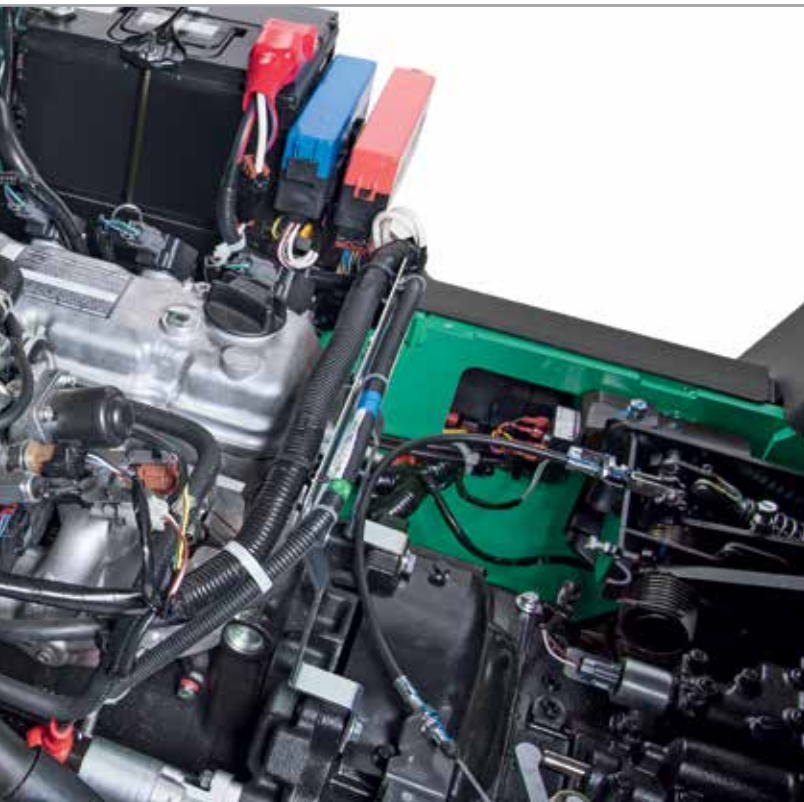

CHARACTERISTICS			FGC35CN		FGC40CN	
1	Capacity at rated load center	lb kg	7,000	3,150	8,000	3,650
2	Capacity at load center - distance	in mm	24	600	24	600
3	Power – fuel type (diesel, gasoline, LP gas, electric)		LP - G/LP		LP-G/LP	
4	Tire type – cushion or pneumatic		Cushion		Cushion	
5	Wheels (x = driven) number front / rear		2x / 2		2x / 2	
DIMENSIONS						
6	Maximum fork height - with rated load	in mm	122	3,100	122	3,100
7	Maximum fork height – with standard 2-stage mast		171	4,350	171	4,350
8	Free fork height – with standard 2-stage mast	in mm	10.6	269	10.6	269
9	Forks – thickness x width x length	in mm	2 x 5 x 42	50 x 125 x 1,070	2 x 5 x 42	50 x 125 x 1,070
	Fork spacing, out-to-out minimum / maximum	in mm	11.1 / 38.9	282 / 987	11.1 / 38.9	282 / 987
10	Tilt, forward / backward	deg	5° / 10°		5° / 10°	
11	Length to fork face	in mm	98.2	2,495	100	2,540
12	Overall width with standard tires	in mm	45.9	1,165	45.9	1,165
13	Height with mast lowered	in mm	83.1	2,110	83.1	2,110
14	Seat height	in mm	44.4	1,130	44.4	1,130
15	Height to top of overhead guard	in mm	82.3	2,090	82.3	2,090
16	Height with mast extended	in mm	178.7	4,540	178.7	4,540
17	Minimum outside turning radius	in mm	82.5	2,095	83.9	2,130
18	Load moment constant	in mm	17.9	455	17.9	455
19	Minimum aisle – 90° stack – zero clearance without load	in mm	100.4	2,550	101.8	2,585
PERFORMANCE						
20	Travel speed, loaded / empty	mph km/h	XXX	XXX	XXX	XXX
21	Lift speed, loaded / empty	fpm mm/s	88.6 / 92.5	450 / 470	88.6 / 92.5	450 / 470
22	Lowering speed, loaded / empty	fpm mm/s	83 / 71	420 / 360	83 / 71	420 / 360
23	Drawbar pull – loaded maximum	lb N	6,228	2,825	6,228	2,825
24	Gradeability – loaded maximum	%	34 / 18		34 / 15	
WEIGHT						
25	Empty	lb kg	10,460	4,740	11,150	5,055
26	Axle load with load, front / rear	lb kg	15,365 / 7,250	2,095 / 990	16,910 / 7,320	2,960 / 1,335
	Axle load without load, front	lb kg	3,365 / 1,525	7,095 / 3,215	3,150 / 1,425	8,000 / 3,630
CHASSIS						
27	Tire size, front (standard)	in	22 x 9 x 16		22 x 9 x 16	
28	Tire size, rear	in	18 x 6 x 12.12		18 x 6 x 12.12	
29	Wheelbase	in mm	59.1	1,500	59.1	1,500
30	Tread width, front (standard tires)	in mm	37	940	37	940
31	Tread width, rear (standard tires)	in mm	36	930	36	930
32	Ground clearance at lowest point of mast	in mm	3.1	80	3.1	80
33	Ground clearance at center of wheelbase	in mm	5.7	145	5.7	145
34	Service brakes	type	drum / foot		drum / foot	
35	Parking brakes	type	hand / mechanical		hand / mechanical	
ELECTRICAL						
36	Engine model		GK25		GK25	
37	Continuous output (S.A.E. gross)	HP kW	62.9	46.9	62.9	46.9
		at rpm	2,700		2,700	
38	Maximum torque (S.A.E. gross)	lb-ft Nm	138.7	188	138.7	188
		at rpm	1,600		1,600	
39	Cylinder / displacement	cu in L	151.8	2,488	151.8	2,488
40	Transmission type		automatic		automatic	
41	Number of transmission speeds, forward / reverse		2 / 1		2 / 1	
42	Battery	volts	12		12	
HYDRAULICS						
43	Relief pressure	psi bar	2,625	181	2,625	181

SAFETY STANDARDS

These trucks meet American National Standards Institute/Industrial Truck Standards Development Foundation, ANSI/ITSDF B56.1. UL-Classified by Underwriters Laboratories, Inc., as to fire and electric shock hazard only; Type LP, LPS (optional), Industrial Trucks. Users should be aware of, and adhere to, applicable codes and regulations regarding operator training, use, operation and maintenance of powered industrial trucks, including:

- ANSI/ITSDF B56.1.
- NFPA 505, fire safety standard for powered industrial trucks - type designations, areas of use, maintenance and operation.
- Occupational Safety and Health Administration (OSHA) regulations that may apply.

Specifications, equipment, technical data, photos and illustrations based on information at time of printing and subject to change without notice. Some products may be shown with optional equipment.

Call-out numbers shown in the diagram below correspond to the first column of the specifications chart.

FGC35CN- FGC40CN

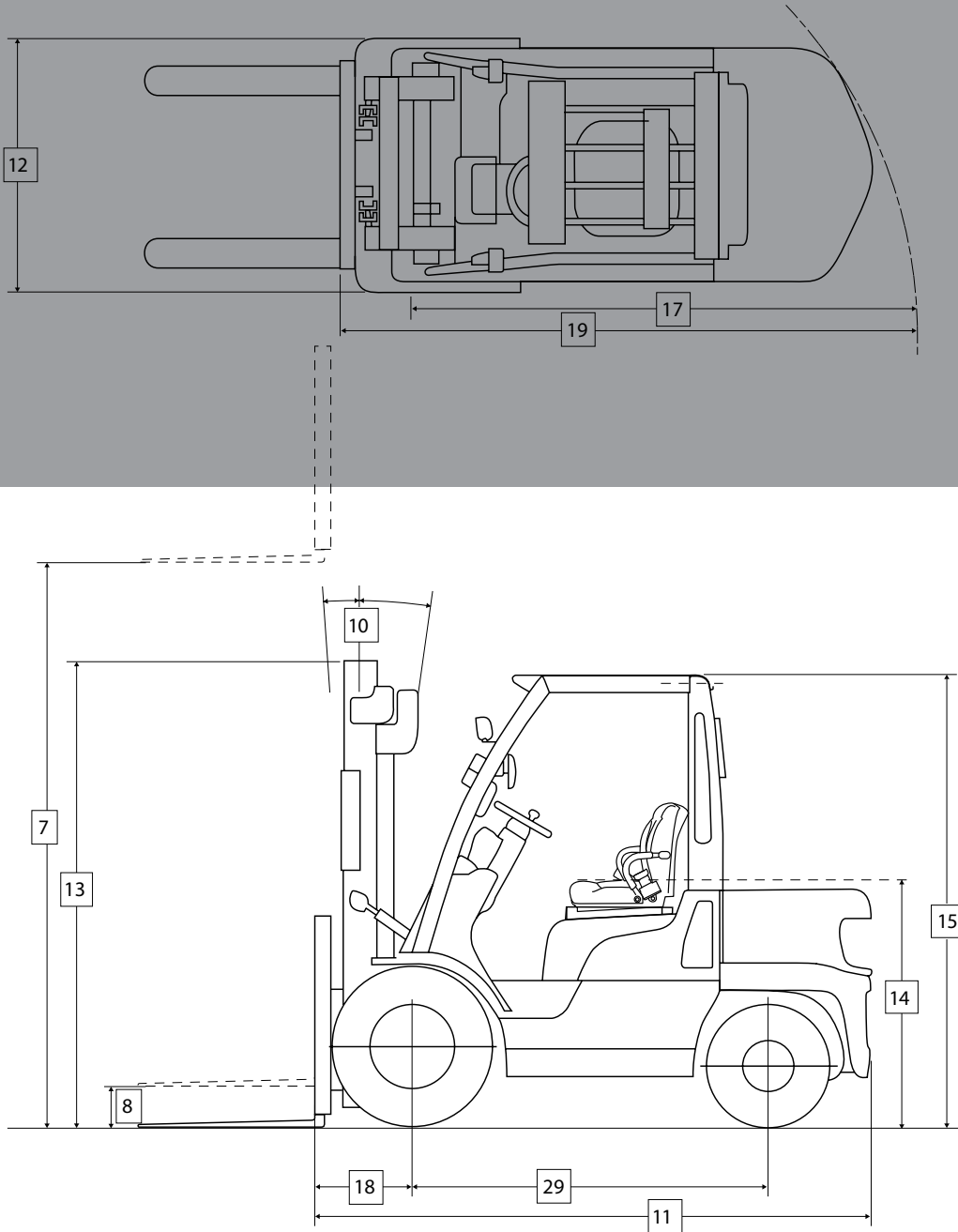

FGC35CN-FGC40CN

7,000-8,000 LB CAPACITY CUSHION TIRE FORKLIFT

Delivering Exceptional Value

More Than 296,000 Parts To Keep You Running

Mitsubishi Forklift Trucks offers several parts programs, all designed to bring you top performance and convenience for your material handling needs. Contact your local dealer to put our services to work for you.

Support To Fit Your Operation

Find out why more companies are relying on Mitsubishi forklift truck dealers to keep their fleet operating at top performance. Our efficiency provides customers with a better return on investment, and qualified service technicians, diverse parts inventory and unparalleled selection of service options can help reduce your total cost of ownership.

Extensive Dealer Network

The Mitsubishi forklift truck dealer network is dedicated to finding the right forklift solution for your business. With more than 300 dealer locations, you can rely on your local dealer to provide the service you need when you need it most.



Manufactured with superior quality and exceptional value, Mitsubishi forklift trucks are supported by an extensive dealer and field support network located throughout North and South America. Don't forget to ask your local Mitsubishi forklift truck dealer about details on factory retail programs, financing plans and additional options and dealer services like planned maintenance and operator training.